

BONALDO

Pi chair

Designer: **Alain Gilles**



Designed by Alain Gilles, the Pi chair has an iconic style and a graphic and rigorous frame which combines minimal style and maximum comfort. The soft and rounded cushion of the seat almost seems to merge with the solid wood frame, while the delicately curved backrest evokes the shape of the mathematical

sign "Pi", harmoniously combining all the elements. The rear legs, with their rounded ends, create an almost graphic connection with the upper line of the backrest. The Pi chair fully reveals its character when it is positioned around a table, becoming the fulcrum of the space with a distinctive and vigorous presence.



Data sheet

1500

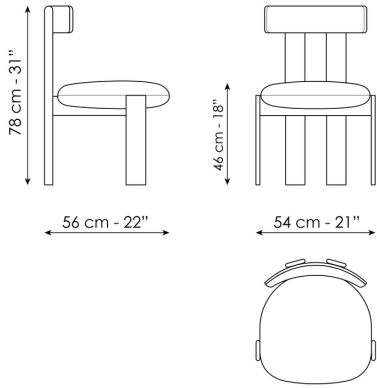

Pi chair

Width: 56cm

Depth: 54cm

Height: 78cm

Finishes

LEGS

Wood



Solid wood
Coal ash

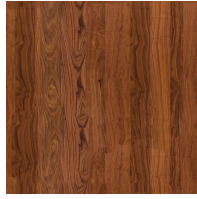

Solid wood
American walnut



Solid wood
Grey ash

Materials, fabrics, leathers, colors and finishes are approximate and may slightly differ from actual ones. You can find the complete collection of Bonaldo fabrics and leathers on the website